



---

# **Closed Loop Control Circuit Design of an Automatic Fire Suppression System**

**Korkoren Kenneth Cheruiyot<sup>1\*</sup>**

<sup>1</sup>*School of Biological and Physical Sciences, Moi University, P.O.Box 3900, Eldoret, Kenya.*

**Author's contribution**

*The sole author designed, analyzed and interpreted and prepared the manuscript.*

**Article Information**

DOI: 10.9734/PSIJ/2017/34433

Editor(s):

- (1) Junjie Chen, Department of Electrical Engineering, University of Texas at Arlington, USA.  
(2) Christian Brosseau, Distinguished Professor, Department of Physics, Université de Bretagne Occidentale, France.

Reviewers:

- (1) Emmanuel C. Agbaraji, Federal Polytechnic Nekede Owerri, Nigeria.  
(2) Prashant Kumar, Savitribai Phule Pune University, India.

Complete Peer review History: <http://www.sciencedomain.org/review-history/20520>

**Original Research Article**

**Received 27<sup>th</sup> May 2017**  
**Accepted 7<sup>th</sup> August 2017**  
**Published 16<sup>th</sup> August 2017**

---

## **ABSTRACT**

Automatic fire suppression systems control and extinguish fires in buildings without human intervention from widespread use of the techniques of measurements and control. Automatic control is achieved here by a design and implementation process. This system implements an early detection system and communicates it to the inhabitants. The system is designed with the input voltage from the smoke detector sensors, BC107B transistor used as the input, Opto-coupler circuit, an alarm and photoelectric detector. For this case we have voltage divider circuit using a Light Dependent Resistor and potentiometer. This design uses a fan instead of a pump as it uses the same principle to test its performance giving standard resistance, Opto-coupler circuit biasing voltage and resistance of the light dependent resistor. Generally the components used are cost effective and feasible.

*Keywords: Smoke detector; transistor; opto-coupler circuit; photo-electric detector; LDR; potentiometer; fan.*

---

\*Corresponding author: E-mail: [korkorenkenneth@gmail.com](mailto:korkorenkenneth@gmail.com);

## 1. INTRODUCTION

### 1.1 Automatic Fire Suppression System

AFS systems control and extinguish fires without human intervention. To do so, they should be designed to have a means of detection, actuation and delivery [1].

Sensors such as smoke or flame detectors may be employed. To provide actuation this may be done by electrical or mechanical means. Delivery is almost always provided by mechanical means e.g. the rupture of polymer tubing to extinguishers [2].

### 1.2 Background

Our poor record in response to fire emergencies has been our major undoing. We have lost many lives by fire outbreaks and property loss in the country through fire has reached unimaginable figure [3].

The worst cases of loss of lives have happened in our secondary schools: in March, 1998-twenty girls died in their dormitories in Bombolulu and later Kyanguli case where more than 50 students lost their lives left many parents pondering about the option of abolishing boarding in secondary schools [4].

The most recent case of loss of lives by fire happened in January, 2009 in Nakumatt downtown store where the death toll hit at least 22 people. Then, we had the Faza disaster where thousands of families were left homeless when fire razed down their homes in September, 2009 [5].

## 2. LITERATURE REVIEW

The first automatic electric fire alarm was invented in 1890 by Francis Robbins Upton (An associate of Thomas Edison although no evidence that Edison contributed to this project). In the late 1930, the Swiss physicist Walter Jaeger tried to invent a sensor for poison gas. He

expected that gas entering the sensor would bind to ionized air molecules and thereby alter an electric current in a circuit in the instrument. His device failed: small concentrations of gas had no effect on the sensor's conductivity. Frustrated, Jaeger lit a cigarette and was soon surprised to notice that a meter on the instrument had registered a drop in current. Smoke particles had apparently done what poison gas could not. Jaeger's experiment was one of the advances that paved the way for the modern smoke detector [6].

The results of recent on-shore pilot trials of the complete closed loop detection/suppression system together with recent modifications of the system to include further performance enhancements. Whilst developed for the marine environment the project was of relevance to any scenario where speed and weight of response is important for the reduction of consequential damage from the fire or extinguishing media in an unmanned situation. Other benefits may include cost effectiveness over some fixed system installations and reduced overall system vulnerability to damage [7].

Prototype system tests show that the system provides early extinguishing of a fire disaster so that damages will be reduced effectively. The installation location must be prearranged of each detector in this system due to localization mechanism not considered. In order to reduce the installation workload and make the system more convenient, automatic localization mechanism is the focus here [8].

The system performs automatic fire fighting task when the system assures the fire occurrence [9].

An automatic fire alert and fire distinguishing system by sensing smoke and heat. Proposed system experimented in the laboratory and noticed its feasibility. It is also seen that the system does not respond if the fire generates very small smoke particles and very small amount of heat. The system does not display properly if two or more than two rooms or blocks are affected at a same time [10].

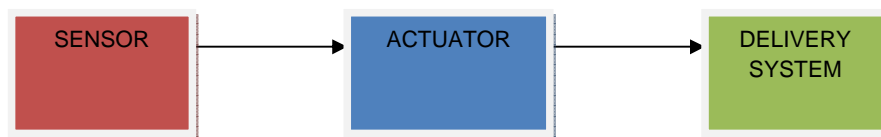

Fig. 1. Automatic Fire Suppression system block diagram [1]

### 3. METHODOLOGY

The system is divided into hardware parts; smoke detector, switching circuit, optocoupler circuit and the main switch. The system is designed to develop system awareness and capability of the smoke detector to detect smoke. A switching circuit is used to process the various sensor signals and control the system actuators accordingly. A firefighting pump replaced by a fan because of the same principles used will be interfaced and interconnected to the system and used to indicate the system status.

The extinguishing agent to be used in this project is water. Following the use of water as an extinguishing agent, class A of fires will be the main target for this project. Electrocutation is further prevented by the incorporation of an optocoupler and mains relay so that power supply is cut off from the mains when smoke is detected and before the release of water.

#### 3.1 System Layout

The block diagram of the hardware implementation of the entire system is shown in Fig. 1. The aim of the design is to illustrate the usage of the fire fighter and its applications and the minimum equipment required to construct the firefighting system is a smoke detector, switching circuit, relays, optocoupler, pump water (fan).

Designed the Automatic Fire Suppression system as per the block diagram (Fig. 2).

#### 3.2 Smoke Detectors

For a smoke detector to function properly and serve the purpose of its design, it must have a sensor to sense the smoke and a very loud electronic horn to wake people up or when incorporated in an AFS system a means of passing the signal to the system so as to provide automatic suppression of fire. Two very basic methods can be employed to design smoke detectors [11].

- Photoelectric detectors and;
- Ionization detectors design techniques.

#### 3.3 BC107B Transistors

Type Designator: BC107B, Material of Transistor: Si, Polarity: NPN, Maximum Collector Power Dissipation (Pc): 0.3 W, Maximum Collector-Base Voltage |Vcb|: 50 V, Maximum Collector-Emitter Voltage |Vce|: 45 V, Maximum Emitter-Base Voltage |Veb|: 6 V, Maximum Collector Current |Ic max|: 0.1 A, Max. Operating Junction Temperature (Tj): 175°C, Transition Frequency (ft): 150 MHz, Collector Capacitance (Cc): 5 pF, Forward Current Transfer Ratio (hFE), MIN: 200, Noise Figure, dB [12].

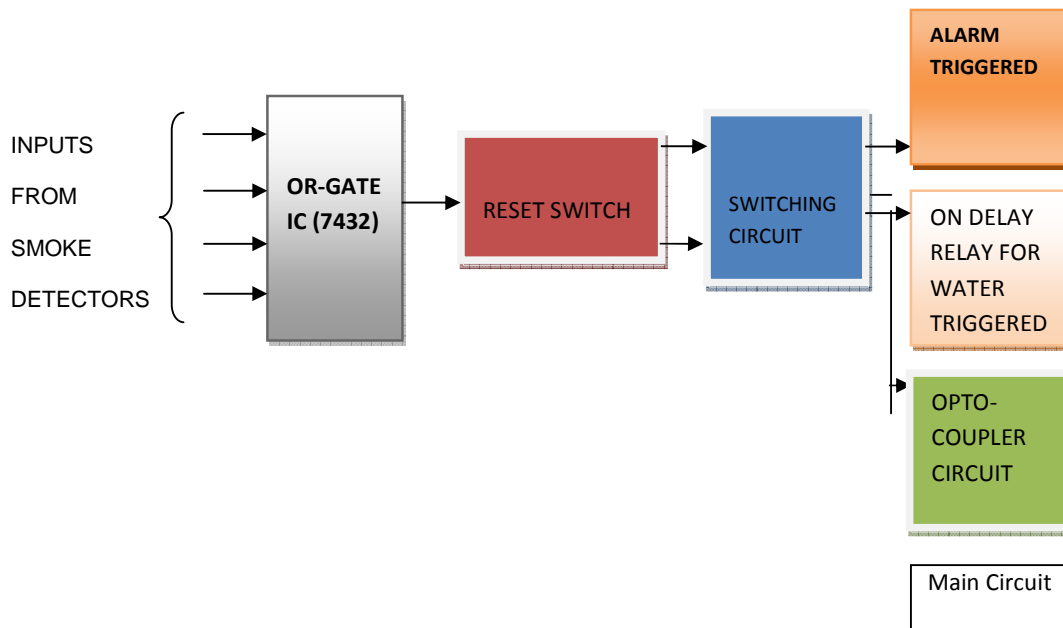

Fig. 2. Block diagram of the automatic fire suppression system

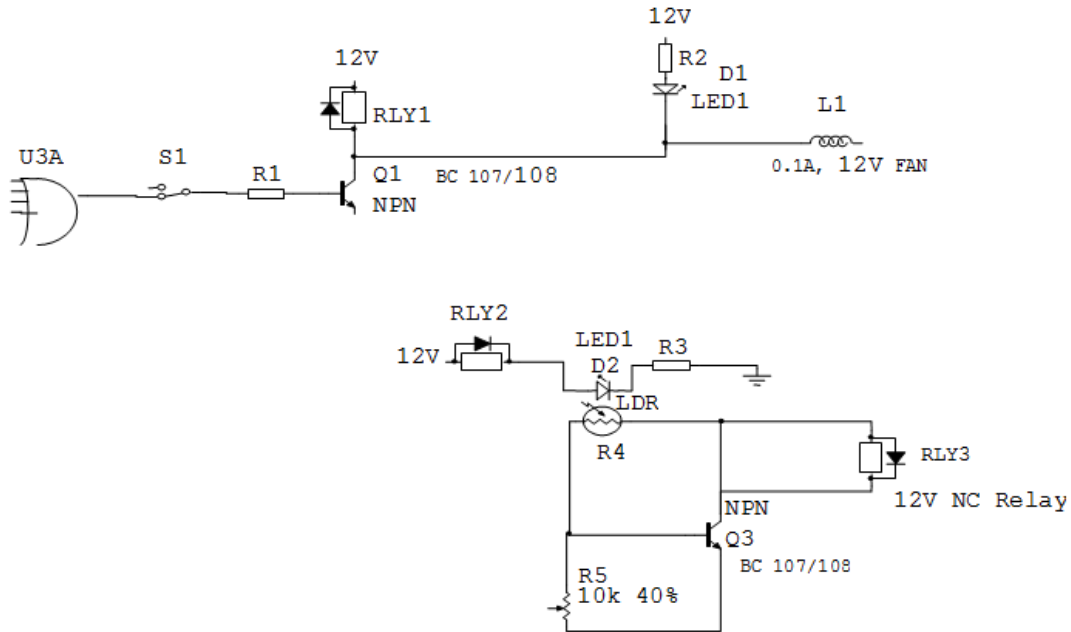

Fig. 3. Control circuit for Automatic Fire Suppression system

### 3.4 Optocouplers

There are many situations where signals and data need to be transferred from one subsystem to another within a piece of electronics equipment without making a direct electrical connection. Often this is because the source and destination are at very different voltage levels, like a microprocessor which is operating from 5V DC but being used to control a triac which is switching 240V AC. In such situations the link between the two must be an isolated one, to protect the microprocessor from overvoltage damage. These use a beam of light to transmit the signals or data across an electrical barrier, and achieve excellent isolation. Optocouplers typically come in a small 6-pin or 8-pin IC package, but are essentially a combination of two distinct devices: an optical transmitter, typically a gallium arsenide LED (light-emitting diode) and an optical receiver such as a phototransistor or light-triggered diac. The two are separated by a transparent barrier which blocks any electrical current flow between the two, but does allow the passage of light [13].

**Inputs:** -OR gate(s) to serve several smoke detectors. Switching circuit designed such that its made of a transistor BC 107/108B, protection diode (IN4001), and resistor (220Ω). With BC107B transistor used at the input which has

$h_{fe} = 40$  m A and the input voltage from the smoke detectors being 9V. Output from smoke detector should be 9v and through a resistor, triggers the switching N/O relay. Once the relay has been activated, the alarm goes ON and the ON-delay relay for water is activated but delayed for 60 seconds. Reset switch is provided to take care of false alarms. Opto-coupler circuit designed by use of an LDR and potentiometer to switch off the mains.

### 4. RESULTS AND DISCUSSION

Design calculations:

Resistance = (Voltage/ current) =  $9V/40$  m A = 2.25K thus 2.2K, for standard resistors. The biasing voltage needed to bias the BC107B transistor at this stage is 3V. Light Dependent Resistor and potentiometer used thus:

$$3V = \left( \frac{14.4YV_{cc}}{14.4 + Y} \right) = 250V$$

Where

14.4Ω - is the resistance of the Light Dependent Resistor when fully illuminated.

Y – is the resistor to be connected with the L.D.R in order to get the voltage divider circuit.

Vcc – is voltage at the collector of the BC107B transistor. A resistance of 250Ω and this can be obtained with a potentiometer. The Automatic Fire Suppression system is able to detect, actuate the delivery mechanism and deliver the extinguishing agent in order to suppress the fire. It even can switch off the mains before releasing water in order to prevent electrocution. To achieve this: the 9V input from the smoke detector is used to bias the BC107B transistor and this in turn energizes the relay connected at the collector terminal. The relay can then close its NO terminal hence, passing the 12V to switch on the alarm LED, switch on the opto-coupler LED, and finally control the water delivery to suppress the fire. To achieve this: the 9V input from the smoke detector is used to bias the BC107B transistor and this in turn energizes the relay connected at the collector terminal. The relay can then close its NO terminal hence, passing the 12V to switch on the alarm LED, switch on the opto-coupler LED, and finally control the water delivery to suppress the fire. This all activities happen without human intervention provided that the smoke detector and the relays are supplied with their respective operating power. Non-flaming fires, photoelectric detectors: 1.5-2.5%/ft and 0.03-0.07 m/s. Input to include OR gates, each terminal picking a signal of 9V.

## 5. CONCLUSION

Current firefighting methods are labour intensive, this mechanism reduces the numbers attending and supporting the incident thus having a beneficial impact on casualty rates. This suppression systems uses off-the-self equipment, is possible at an accuracy that has the potential to radically improve recoverability in terms of the time at which a measured response may be instigated, and the amount of extinguishing agent deployed. The successful demonstration of a closed-loop response using simple components easily found in our laboratories represents a quick win for cheap and affordable systems.

Photoelectric detector implemented meets the dual parameter approach e.g. obscuration and velocity in unventilated rooms. This project achieved the detection, actuation and delivery of fire suppression without human intervention.

## COMPETING INTERESTS

Author has declared that no competing interests exist.

## REFERENCES

1. Fire Events Database Update for the Period 2010–2014: 2016 technical report.
2. Guidance notes on fire-fighting systems- January, 2017.
3. Adelaide Eastern Region Fire Handbook: July, 2008.
4. Available:<https://www.standardmedia.co.ke/article/2000064691/tragedy-relives-memories-of-dormitory-deaths>
5. DREF Operation n° MDRKE008 GLIDE n° AC-2009-000036-KEN & AC – 2009-000037-KEN, 10 February; 2009.
6. Neil Cumming: A book on security.
7. James LD Glockling, Mike Edwards. Development of a robotic local suppression system for the marine environment.
8. Santosh P. Patange, Sagar V. Yadav. Design and implementation of automatic fire alarm system based on wireless sensor networks.
9. Amani Osman Khojali Eltayeb: Design and Implementation of Automatic Fire Fighting System.
10. Kausik Sen, Jeet Sarkar, Sutapa Saha, Anukrishna Roy, Dipsetu Dey, Sumit Baitalik, Chandra Sekhar Nandi. Automated fire detection and controlling system. International Advanced Research Journal in Science, Engineering and Technology; 2015.
11. Nichole L. Carriere. Market analysis of smoke detection and applications.
12. AllTransistors(C) 2015 BC107B Datasheet.
13. Electus Distribution Reference Data Sheet: OPTOCOU.PDF.

© 2017 Cheruiyot; This is an Open Access article distributed under the terms of the Creative Commons Attribution License (<http://creativecommons.org/licenses/by/4.0>), which permits unrestricted use, distribution, and reproduction in any medium, provided the original work is properly cited.

Peer-review history:  
The peer review history for this paper can be accessed here:  
<http://sciencedomain.org/review-history/20520>